



**KONGSBERG**  
AUTOMOTIVE

Enhancing the driving experience

# STEERING COLUMNS

Completely tailored from our modular system according to customer specifications with full in-house design, development and validation services.

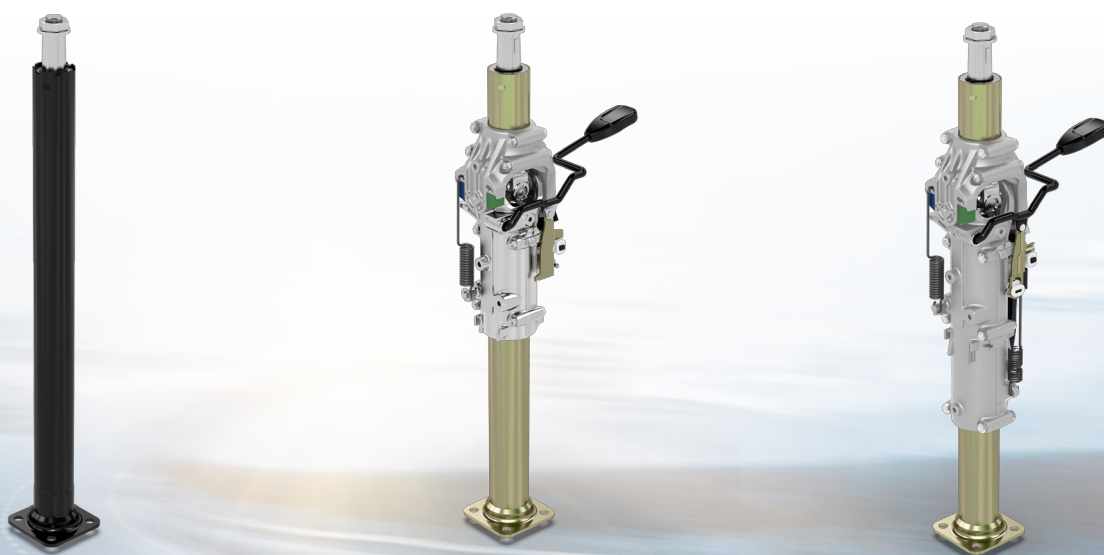

Genuine Kongsberg Automotive Products

# STEERING COLUMNS

## PRODUCT DESCRIPTION

Kongsberg Automotive offers a full range of fixed, tilt and telescopic steering columns, designed to withstand the most challenging environments for off-road vehicles. With our unique modular design, all columns provide best-in-class ergonomic working conditions for the driver.

### BENEFITS

- Fully developed, tooled up and validated concepts
- High component commonality, enables short lead time on launches and modification
- Minimal capital and design investment
- Unique modular design our steering column range enables best-in-class ergonomic working conditions for the driver
- Highly experienced engineering and manufacturing team with over 20 years of market & product knowledge

Kongsberg Automotive offers completely tailored steering columns from our modular system according to customer specifications with full in-house design, development and validation services.

### FEATURES

- KA's unique modular, self-supported designs
- Modular building blocks for tilt and telescope functions
- Variable steering column length
- Variable position of tilt and telescope
- Variable angles for tilt function and step in and step out positions
- Tilt locking system, incremental or infinity locking
- Telescope function with infinite positioning, low or high telescope positions
- Compatible with all types of steering wheel connections
- Single hand lever, foot pedal or cable operated release
- Compatible with all types of hydraulic pump interfaces
- Vibration damping systems
- Optional driver control modules, switches, horn module, covers and displays

## GENERAL SPECIFICATIONS

KA columns are available with covers, bellow and a range of integrated switches and shifters.

Switches can be fixed direct to the steering tube and positioned with index hole

### STANDARD ISO 5010 AND SAE J1814

- The specification of all steering columns is according to ISO 5010 and SAE J1814.
- All columns meet Kongsberg Automotive product specification for off road vehicles, agricultural tractors and construction equipment

### Test and Validation

- All columns are tested and validated according to Kongsberg Automotive product specification and above mentioned standards

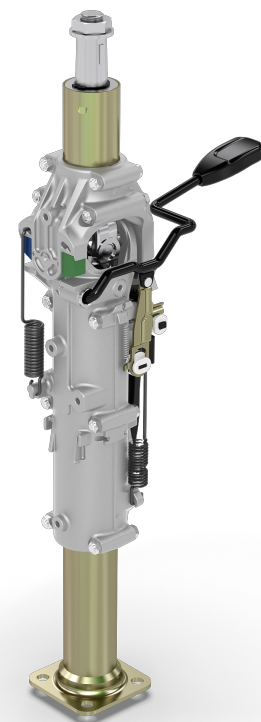

## STEERING COLUMN RANGE SUMMARY



F 100



T200



T350



T400



T425

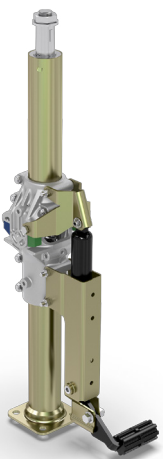

T450



TT550



TT600



TT700

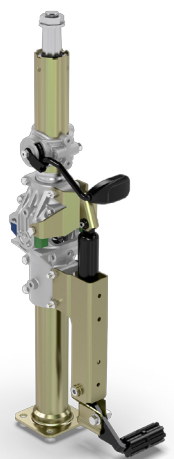

TT750



XT850



XT950



XT1050



TT600



XT1050M

## STANDARD STEERING COLUMNS



### FIXED COLUMN F100

Steering Wheel Connection	Part no	Standard Column Lengths							Optional Cover/ Bellows	
		in millimeter							With	Without
A01	21488	-100	-200	-300	-400	-500	-600	-700	-1	-0
A04	21489	-100	-200	-300	-400	-500	-600	-700	-1	-0
A05	21490	-100	-200	-300	-400	-500	-600	-700	-1	-0

\*Option of covers/bellow are only available on column lengths from 500mm.



### TILT COLUMN T400

Steering Wheel Connection	Part no	Standard Column Lengths				Optional Cover/ Bellows	
		424mm	500mm	600mm	700mm	With	Without
A01	21500	-424	-500	-600	-700	-1	-0
A04	21501	-424	-500	-600	-700	-1	-0
A05	21502	-424	-500	-600	-700	-1	-0

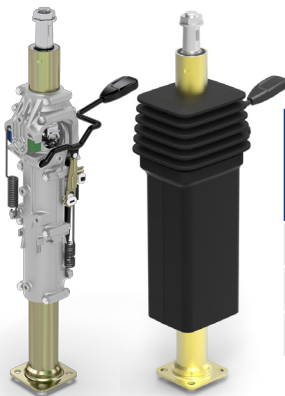

### TILT TELE COLUMN TT600

Steering Wheel Connection	Part no	Standard Column Lengths				Optional Cover/ Bellows	
		424mm	500mm	600mm	700mm	With	Without
A01	21503	-424	-500	-600	-700	-1	-0
A04	21504	-424	-500	-600	-700	-1	-0
A05	21505	-424	-500	-600	-700	-1	-0

# STEERING COLUMNS FEATURES

## CONNECTION TO STEERING WHEEL

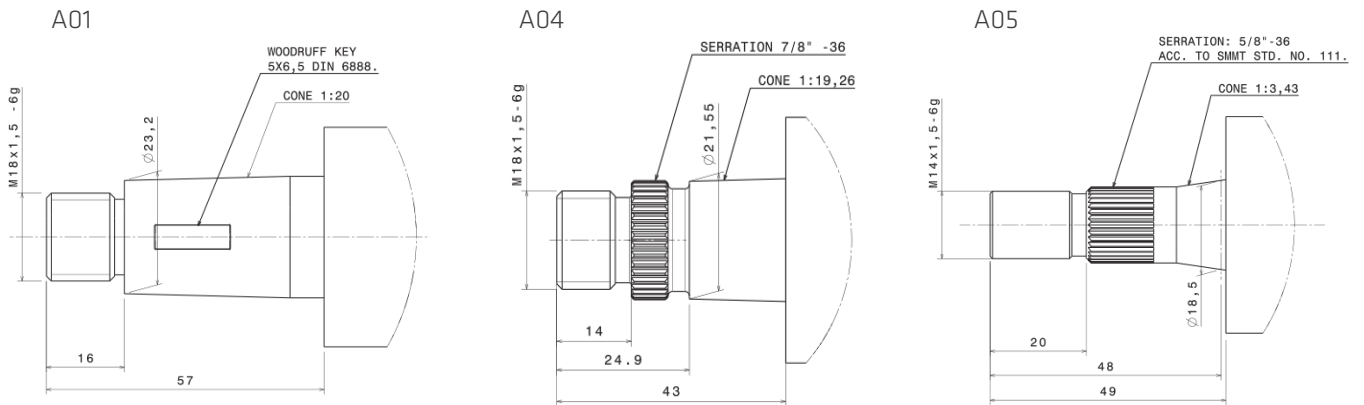

## TILT ANGLES

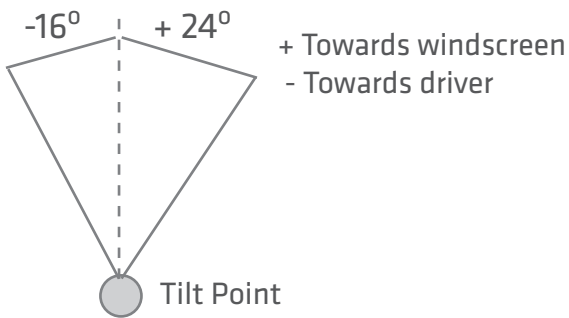

## CONNECTION TO FLOOR AND PUMP

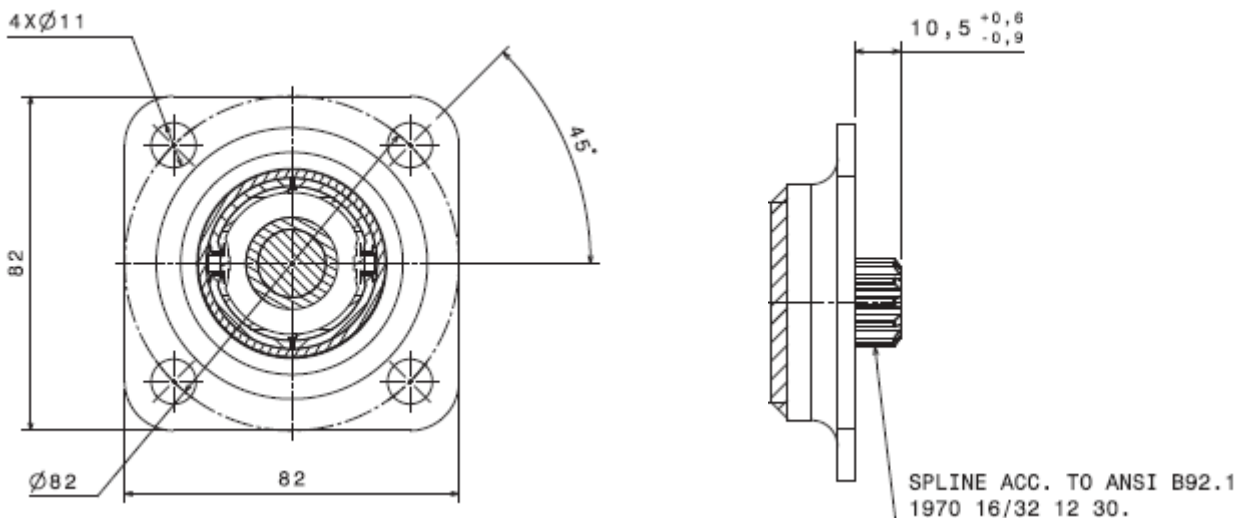



**KONGSBERG**  
AUTOMOTIVE

Enhancing the driving experience

Kongsberg Automotive | Sweden  
Hestravägen 1  
SE-51455 Ljungsarp  
Tel: +46 321 55 33 50

[www.kongsbergautomotive.com](http://www.kongsbergautomotive.com)