

MH-2000 CONTROL

MULTI-TURN HAND THROTTLE CONTROL



AT A GLANCE

- > INNOVATIVE DESIGN ALLOWS FOR EASE OF INSTALLATION REGARDLESS OF APPLICATION OR CONFIGURATION
- > ADJUSTABLE LOCKING COLLAR FRICTION MECHANISM HOLDS POSITION RESISTANT TO VIBRATION
- > PATENTED vSENSE™ HALL EFFECT NON-CONTACT SENSOR PROVIDES FINITE ACCURACY AND RELIABILITY FOR LOW AND HIGH RPM SETTINGS
- > INDUSTRY LEADING CYCLE LIFE
- > FULLY SEALED AND RESISTANT TO ENVIRONMENTAL AND CHEMICAL INTRUSION
- > CLOCKWISE AND COUNTER-CLOCKWISE AVAILABLE
- > "QUICK" RETURN TO IDLE FEATURE

PRODUCT DESCRIPTION

The MH-2000 Multi-Turn Hand Throttle Control is the technically enhanced next generation of a recognized industry standard control. The MH-2000 is intended for use with electronic engines as a remote, hand operated control for engine RPM. Designed for ease of installation and flexibility for ergonomic positioning and mounting per a customer's specifications, this product is adaptable for a wide range of electronic throttle applications requiring a robust, durable design, with finite adjustment capabilities. Product applications include buses, fire trucks, generator sets, trucks, agricultural tractors, and construction equipment.

The compact, fully sealed single component system provides extended service life in the harshest environments. With multiple sensor output options, the industry leading Kongsberg Automotive vSense non-contact sensor can be calibrated to meet the customer's exact requirements.

This device can be used as a stand alone product or it can be used in conjunction with other Kongsberg Automotive Power Products Systems products to create a complete control system for virtually any type of heavy duty vehicle.

MH-2000 CONTROL

MULTI-TURN HAND THROTTLE CONTROL



PRODUCT SPECIFICATIONS

PARAMETERS

Operating Voltage:

Output Range
(programmable) within:

Wide Open Throttle (WOT):

Operating Temperatures:

Storage Temperature:

Salt Spray:

Solid Objects and Water Ingress:

Connector:

Specification Compliances:

SPECIFICATIONS

Analog - 5V +/- 0.5V

PWM - 7.5V to 32V

Minimum >7% of supply voltage

Maximum <90% of supply voltage

720°

-40°C to +85°C

-54°C to +85°C

96 Hours

IP67

Metripack connector standard
(harness provides options)

ASTM B633; ASTM B117-97, SAE J726, SAE
J1843, SAE J1455, KA PS-462, PS-00522

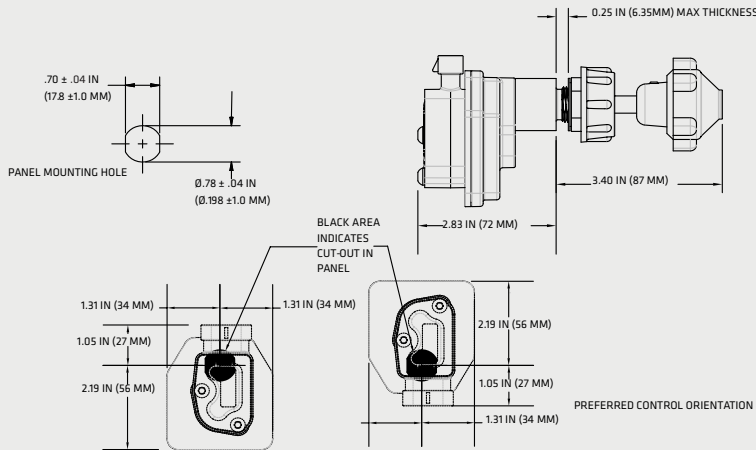

OPTIONS

- > INDUSTRY LEADING AND PATENTED VSENSE™ HALL EFFECT NONCONTACT SENSOR PROVIDES FINITE ACCURACY AND RELIABILITY FOR LOW AND HIGH RPM SETTINGS.
- > ANALOG AND PWM SENSORS AVAILABLE
- > ROBUST, DURABLE DESIGN
- > ADJUSTABLE LOCKING COLLAR FRICTION MECHANISM HOLDS POSITION RESISTANT TO VIBRATION
- > CLOCKWISE AND COUNTERCLOCKWISE AVAILABLE
- > (2)TURNS FROM IDLE TO WOT
- > "QUICK"RETURN TO IDLE
- > DYNAMIC IP67 SENSOR
- > OPTIONAL OUTPUTS AVAILABLE
- > MULTIPLE CONNECTOR OPTIONS

ENGINE	PREVIOUS MULTI-TURN P/N	MH-2000	# TURNS	TURN DIRECTION (IDLE TO FULL THROTTLE)	NOMINAL IDLE (DUTY CYCLE OR %VREF)	NOMINAL WOT (DUTY CYCLE OR %VREF)	OUTPUT	HARNESS (IF REQ'D)
Caterpillar	310730(1)	310730	1.75	CCW	16%	82%	Single PWM	Not Required
	311421(2)	317902-10CP-27	2	CCW	16%	82.5%	Single PWM	318080-7002(A)
	311421-001(2)	317902-10CP-63	2	CCW	7.5%	92.5%	Single PWM	318080-7002(A)
Navistar	310714-008(3)	310714-008	2.25	CW	10%	90%	Single Analog	Not Required
	310714-001(4)	317901-10CS-61	2	CW	10%	75%	Single Analog	318307-1002CW1(C)
	310714-004(5)	317902-10CS-64	2	CCW	10%	90%	Single Analog	318308-1002CCW1(C)
Cummins	310714-001	317901-10CS-61	2	CW	10%	75%	Single Analog	318307-1002CW1(C)
	310714-001	317901-10CS-64	2	CW	10%	90%	Single Analog	318307-1002CW1(C)
	310714-004	317902-10CS-61	2	CCW	10%	75%	Single Analog	318308-1002CCW1(C)
	310714-004	317902-10CS-64	2	CCW	10%	90%	Single Analog	318308-1002CCW1(C)
	311440	317902-10CI-01	2	CCW	10%	75%	Single w/IVS	318311(B)
	n/a	317901-10CD-00	2	CW	Idle #1 22% Idle #2 11%	WOT #1 84% WOT #2 42%	Dual Analog	n/a n/a
	n/a	317902-10CD-00	2	CCW	Idle #1 22% Idle #2 11%	WOT #1 84% WOT #2 42%	Dual Analog	n/a n/a
John Deere	310714-002	317901-10CS-03	2	CW	12%	88%	Single Analog	318307-1002CW1(C)
	310714-005	317902-10CS-03	2	CCW	12%	88%	Single Analog	318308-1002CCW1(C)
	310714-007	317901-10CS-03	2	CW	12%	88%	Single Analog	318307-1002CW1(C)
Detroit Diesel	310714-001	317901-10CS-64	2	CW	10%	90%	Single Analog	318307-1002CW1(C)
	310714-004	317902-10CS-64	2	CCW	10%	90%	Single Analog	318308-1002CCW1(C)
	310714-008	310714-008	2.25	CW	10%	90%	Single Analog	Not Required

Model: (1) 8VDC Input (2) 24VDC
PWM = Pulse Width Modulation

Max Input Connectors: (A) 3-Pin Round Deutsch, (B) 6-Pin Deutsch, (C) 3-Pin Weatherpack
MH-2000 utilizes a hall effect sensor; therefore, resistance is N/A.

CHINA: 1288 KANGQIAO EAST ROAD, 201319 PUDONG, CHINA // T: +86 21 581 34411

EUROPE: HLAVNÁ 48, 952 01 VRÁBLE, SLOVAKIA // T: +42 1 377 911 542

NORTH AMERICA: 300 SOUTH COCHRAN PO BOX 588 WILLIS, TX 77378, USA // T: +1 936 856 2971

WWW.KONSGBERGAUTOMOTIVE.COM



MH-2000 MULTI-TURN HAND THROTTLE CONTROL PIN-OUTS

MH-2000 MULTI-TURN THROTTLE CONTROL SINGLE OUTPUT PIN-OUT INFORMATION	
6(A)	APS SIGNAL
5(B)	GND
4(C)	APS SUPPLY 5V
3(D)	
2(E)	
1(F)	
APPLICABLE PART NUMBERS 317901-10CS-61 and 317902-10CS-61 317901-10CS-64 and 317902-10CS-64 317901-10CS-03 and 317902-10CS-03	

MH-2000 MULTI-TURN THROTTLE CONTROL DUAL OUTPUT PIN-OUT INFORMATION	
6(A)	APS SIGNAL 1
5(B)	GND 1
4(C)	APS SUPPLY 5V
3(D)	APS SUPPLY 5V
2(E)	APS SIGNAL 2
1(F)	GND 2
APPLICABLE PART NUMBERS 317901-10CD-00, 317902-10CD-00	

MH-2000 MULTI-TURN THROTTLE CONTROL SINGLE W/IVS OUTPUT PIN-OUT INFORMATION	
6(A)	APS SIGNAL
5(B)	GND
4(C)	APS SUPPLY 5V
3(D)	IVS 3
2(E)	IVS 2
1(F)	IVS GND
APPLICABLE PART NUMBERS 317901-10Ci-01, 317902-10Ci-01	

MH-2000 MULTI-TURN THROTTLE CONTROL SINGLE OUTPUT PWM PIN-OUT INFORMATION	
6(A)	
5(B)	GND
4(C)	APS SUPPLY 7.5 - 32V
3(D)	
2(E)	
1(F)	APS SIGNAL
APPLICABLE PART NUMBERS 317902-10CP-27, 317902-10CP-63	

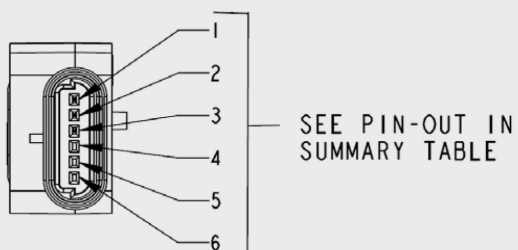

BENEFITS

- > INNOVATIVE DESIGN ALLOWS FOR EASE OF INSTALLATION REGARDLESS OF APPLICATION OR CONFIGURATION
- > FULLY SEALED AND RESISTANT TO ENVIRONMENTAL AND CHEMICAL INTRUSION IN THE HARSHTEST ENVIRONMENTS INDUSTRY LEADING CYCLE LIFE

OPTIONS

- > SENSOR OUTPUT
- > CONNECTOR TYPE
- > UTILIZES METRI-PACK CONNECTOR AS STANDARD CONNECTOR
- > LEAD LENGTH