

LoBC BUMP CONTROL

LEVER OPERATED ELECTRONIC BUMP CONTROL



AT A GLANCE

- > A LEVER OPERATED CONTROL, SUITABLE FOR ANY OFF HIGHWAY VEHICLE APPLICATION
- > ESPECIALLY SUITED FOR APPLICATIONS IN A HEAVY DUTY ENVIRONMENT
- > SPRING RETURN ACTION SUITABLE FOR ANY FUNCTION THAT REQUIRES 'BUMPING' UP OR DOWN
- > CAN BE CONFIGURED FOR ANALOGUE, PWM OR CANBUS SENSOR OUTPUTS
- > NON-CONTACT, HALL EFFECT SENSOR PROVIDES POSITION SENSING WITH ACCURACY AND RELIABILITY

PRODUCT DESCRIPTION

The LoBC – Lever Operated Bump Control is intended for use on any function which requires a parameter to be 'bumped' up or down. This device can be used as a stand alone product or it can be used in conjunction with Kongsberg Automotive Throttle pedal products to create a complete control system for virtually any type of heavy duty vehicle.

It features the vSENSE™ non-contact sensor with patent-pending technology, configurable for a wide range of sensor output types.

The Kongsberg Automotive vSENSE™ non-contact, programmable Hall effect sensor seals out contaminants to provide enhanced reliability in all environments. With no moving parts to wear over time, the vSENSE™ sensor sets a new standard for accuracy and durability.



LoBC BUMP CONTROL

LEVER OPERATED ELECTRONIC BUMP CONTROL



PRODUCT SPECIFICATIONS

PARAMETERS	SPECIFICATIONS
RATED LIFE	> 1, 000,000 CYCLES
OPERATING TEMPERATURE	-40°C TO +85°C
IP RATING	IP67

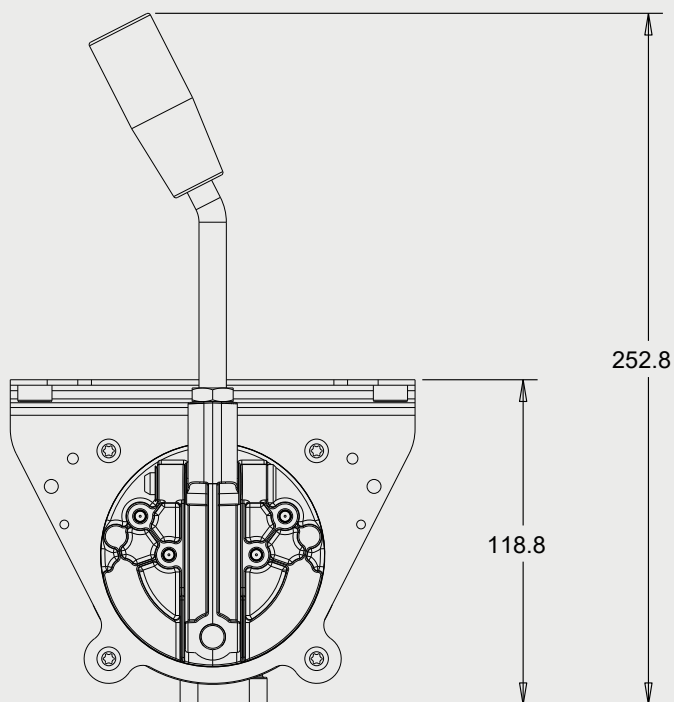
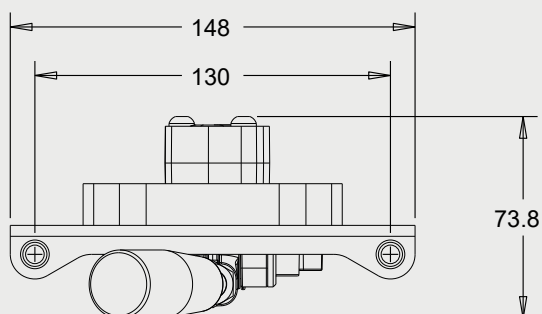

FEATURES

- > EASY, PANEL-MOUNT INSTALLATION
- > INTEGRATED SENSOR WITH METRIPACK 150 CONNECTOR

OPTIONS

- > SENSOR OUTPUT CAN BE CONFIGURED FOR A MULTITUDE OF APPLICATIONS