



KONGSBERG
AUTOMOTIVE

ACCELERATING PROGRESS

ER8000 ELECTRONIC ROCKER PEDAL WITH vSENSE™ TECHNOLOGY



AT A GLANCE

- A robust design ideally suitable for demanding off-highway pedal applications requiring a rocker type action
- Quadruple compression spring design ensures complete reliability and constant pedal forces over the vehicle lifetime
- Unique hysteresis element design provides smooth, predictable and comfortable operator control
- vSENSE™ Hall effect non-contact sensor provides position sensing and switching accuracy and reliability
- Fully user customizable to fit a wide range of applications

Product Description

The Kongsberg Automotive ER8000 series pedal systems offer easy installation for any off-highway vehicle application requiring an electronic pedal with a bi-directional, 'rocker' type of action.

The mechatronic pedal features the vSENSE™ non-contact sensor with patent-pending technology, configurable for analog output or electronic switches. Built to exceed all applicable industry standards and requirements, this rugged pedal and sensor system can withstand extreme

off-road environments while ensuring precise control and superior performance.

The ER8000 pedal benefits from Kongsberg Automotive's unique 'direct-drive' of the sensor, providing enhanced reliability in all environments. With no moving parts to wear over time, the vSENSE™ sensor sets a new standard for accuracy and durability, exceeding IP67 seal rating by performing under dynamic rather than static conditions.

Contact:

China: 1288 Kangqiao East Road, 201319 Pudong, China
Europe: Hlavná 48, 952 01 Vrāble, Slovakia
North America: 300 South Cochran PO Box 588 Willis, TX 77378, USA

Tel: +86 21 581 34411
Tel: + 421 377 911 542
Tel: + 1 936 856 2971

ACCELERATING PROGRESS

ER8000 ELECTRONIC ROCKER PEDAL WITH vSENSE™ TECHNOLOGY

Product Specifications

Parameters	Specifications
Rated life	5,000,000 cycles
Typical pedal actuation torques: Away from neutral position Full-pedal-travel	Approx 6Nm Approx 11Nm
Load rating	1550N (350lb)
Specification compliance	FMVSS124, SAE J1455, SAE J1113
Operating temperature	-40°C to +85°C

Product Dimensions

ER8000 SERIES ELECTRONIC ROCKER PEDAL

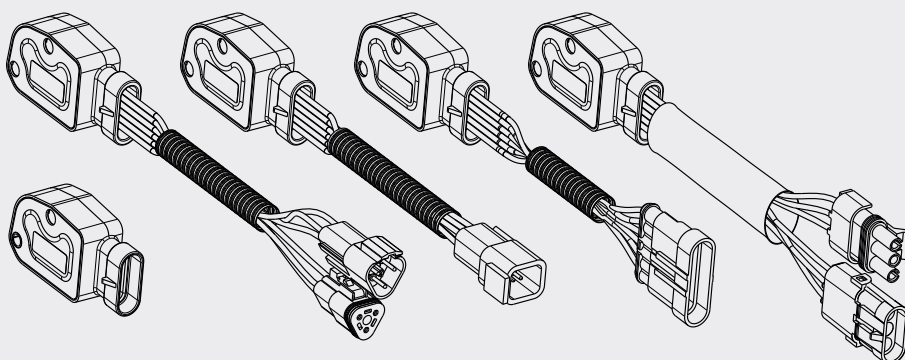
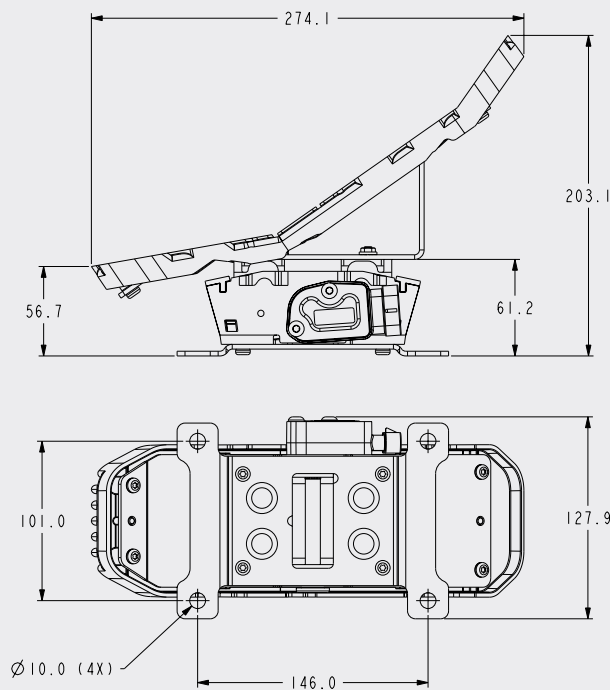

ER8000 features

- Up to $\pm 12^\circ$ pedal travel from the central rest position
- Easy mounting to the cabin floor
- Composite end caps prevent intrusion of debris
- Unique design ensures smooth operation over lifetime, without freeplay or noise

ER8000 options

- Allows easy fitment of custom treadle geometry, if required
- Sensor output
- Sensor connection
 - Integrated Metripack 150
 - Customized connectors on flying leads