

Hands-on Control

B10 HAND CONTROL



AT A GLANCE

The flexible B10 Control can serve a wide range of applications, including:

- Proven Reliability
- Power Take-Off
- Throttle Control
- Mechanical Shifting Control
- Basic On-Off Function
- Rugged construction for smooth operation in harsh environments

Product Description

The Kongsberg Automotive B10 Hand Control is designed to provide a robust solution to a wide range of control requirements, including power take-off applications, throttle controls, mechanical shifting, or basic on-off functions.

The B10 Control can operate independently, or as an integrated system connected to a Kongsberg Automotive heavy duty pedal (HDP). When combined with our cables, these control systems are designed to perform

smoothly in the harshest environments, while providing excellent operator feedback.

The Kongsberg Automotive B10 Hand Control combines flexibility, durability and reliability to meet the highest performance requirements of construction equipment and specialty vehicle manufacturers.

Contact:

Europe: Hlavná 48, 952 01 Vrábľe, Slovakia
North America: 300 South Cochran PO Box 588 Willis, TX 77378, USA

Tel: + 421 377 911 542 861
Tel: + 1 936 856 2971

www.kongsbergautomotive.com, info.pps@ka-group.com

Product Specifications

Technical specifications	
Material	Die cast Mazak Body Steel lever shaft
Mechanical advantage	5:1
Lever stops	15° increments
Lever rotation	Lever rotation 138° maximum
Lever length	144mm / 180mm Options available
Lever offset	48mm std Options available
Cable travel	75 mm maximum
Detents	Optional Custom positions
Friction adjustable	Adjustable friction setting Positive lock model available
B10 Hand Control	Part number
Control - Bent Lever	224358
Control - Straight Lever	224350
Cable for use with B10	206519/Length required

Mounting details

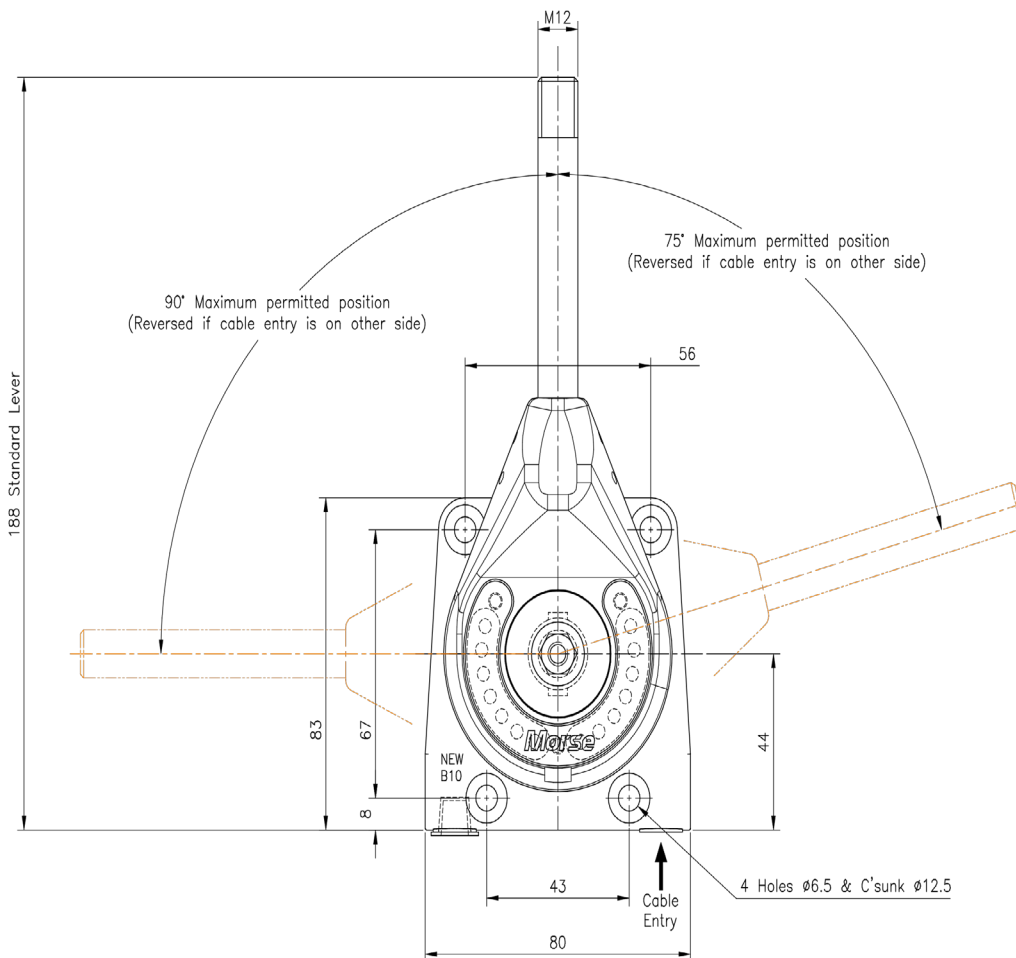

OPTIONS

- The B10 Control can operate independently, or as an integrated system connected to a Kongsberg Automotive heavy duty pedal (HDP).
- Push-pull and pull only versions available.
- Black or silver finish
- Can be supplied with cables ready fitted for ease of assembly.
- Adjustable stops for lever and cable travel.
- Wide range of lever options available