

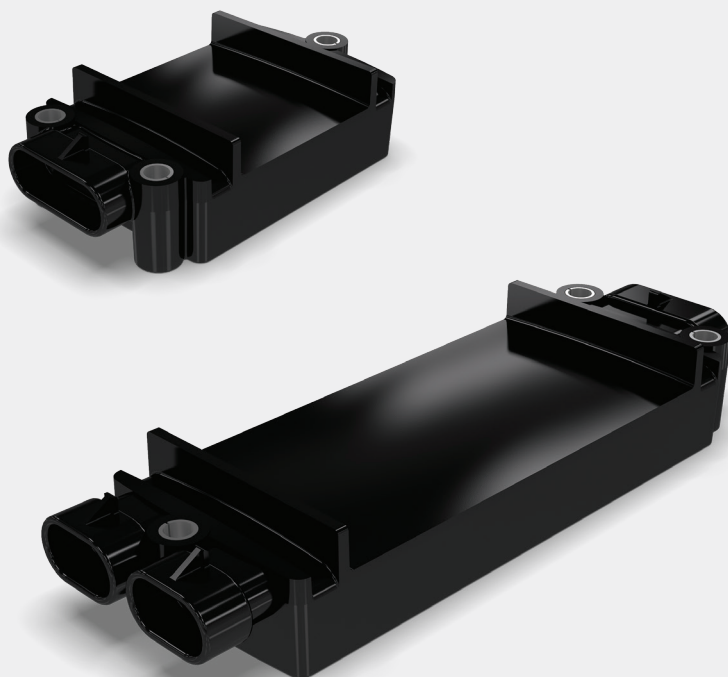

# ELECTRONIC SYSTEMS

## SMART KAN INTERFACE MODULE - SKIM



### AT A GLANCE

- Family of configurable and expandable input/output (I/O) Modules
- 2 or 8 I/O as standard
- CAN bus Communications
- I/O's can be any combination of analog or digital inputs, frequency generator or pulse width modulated (PWM) outputs
- User-Friendly Windows based PC Configuration Tool
- 12/24 V Compatibility
- J1939 or NMEA 2000 CAN protocols are supported
- Integrated Metri-Pack connectors

### Product Description

The SKIM (Smart KAN Interface Module) is the perfect platform to empower your electronics with flexibility and control. The SKIM module provides engineers with the flexibility and freedom to design electronic control systems for vehicular applications and stand alone applications. This unique product is a flexible module that interfaces between external devices and a CAN (J1939) network. The SKIM is a family of modules with configurable I/O's (Input/Output) that accept either analog, digital or frequency input signals or can generate frequency or PWM output signals, and can communicate with other CAN-based modules.

Each I/O can be individual configured as either an Input or an Output with KA's user friendly PC Configuration Tool. The SKIM is also designed for universal (12/24VDC) applications.

These compact, fully sealed units are IP67 rated to provide extended service life in the harshest environments. The SKIM is available in either 2 or 8 I/O's (depending on model), and have integrated mounting holes and wire tie locations for easy mounting in any application. There are several accessories available for the SKIM including a PC Configuration Tool, mating connector kits and wiring harnesses.

### Contact:

Europe: Christopher Martin Road, Basildon, Essex SS14 3ES, UK  
North America: 300 South Cochran PO Box 588 Willis, TX 77378, USA  
Electronics: 90 - 28e Rue Grand-Mère (Québec) G9T 5Z8 Canada

Tel: + 44(0) 1268 522 862  
Tel: + 1 936 856 2971W  
Tel: + 1 819 533 3201

[www.kongsbergautomotive.com](http://www.kongsbergautomotive.com), [info.pps@ka-group.com](mailto:info.pps@ka-group.com)

# ELECTRONIC SYSTEMS

SMART KAn INTERFACE MODULE - SKIM

## Product Specifications

### Mounting and dimensional information

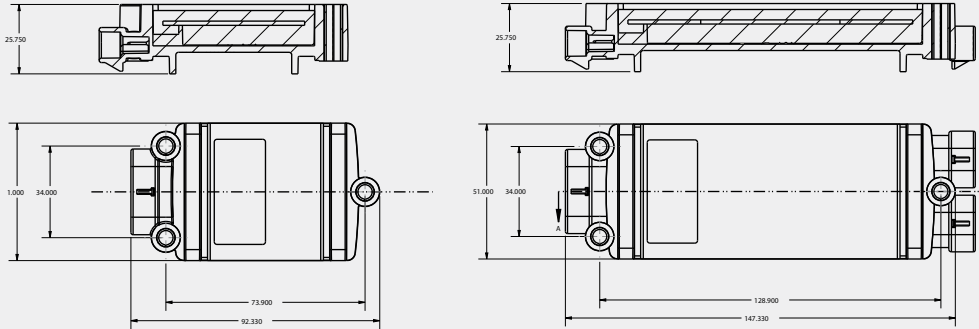

### Specifications and technical data

INPUTS						
Digital Pulse Counter: Frequency Input Mode	Virtual Instrument	Signal Level	Frequency Range	Resolution	Accuracy	
	Pulse Counter Frequency Meter	4 to 32V	1 to 2500 Hz	50 ns	± 0.01%	
Digital Input Mode	Virtual Instrument	Signal Level				
	Switch Input	4 to 32V				
Digital Input Mode	Virtual Instrument	Range	Resolution	Accuracy		
	Volt Meter	0 to 12V 0 to 32 V	12mV 32 mV	± 1% ± 2%		
Resistance Mode	Virtual Instrument	Range	Accuracy	Precision		
	Ohm Meter	0 to 400 Ω	± 2%	± 1Ω		
Current Input Mode	Virtual Instrument	Range	Accuracy	Precision	Shunt to GND	
	Amp Meter	0 to 25 mA	± 1%	± 50 uA	200 Ω	
OUTPUTS						
PWM Output Mode	Virtual Instrument	Range	Resolution	Accuracy	Optional Pull Up Load	Duty Cycle
	PWM Output	0.067Hz to 25 kHz	50 ns	± 0.01%	6.8kΩ	16 Bits
Frequency Output Mode	Virtual Instrument	Range	Resolution	Accuracy	Optional Pull Up Load	Duty Cycle
	Square Wave Output	0.067Hz to 25 kHz	50 ns	± 0.01%	6.8kΩ	50%
Digital Output Mode	Virtual Instrument	Optional Pull Up Load	Low Level Sink Current			
	Low Side Output	6.8kΩ	750 mA			
COMMUNICATIONS						
CAN Interface	Data rate (baud)	Arbitration	Bytes	Repetition Rate Transmission		
	Low Side Output	29 Bits (2.0B)	8	10 ms to 2 s		
PC CONFIGURATION TOOL / STARTER KIT & PART NUMBERING INFORMATION						
PC Configuration Tool - Separate: Part Number - S01463:						
Starter Kit (Contents): Part Number - E02723 - PC Configuration Tool CD - 2 I/O SKIM - 8 I/O SKIMv - Programming Harness - 10 Hours of Technical Support - Carrying Case		Individual SKIM Part Numbers 2 I/O SKIM: Part Number - E02427 8 I/O SKIM: Part Number - E02619				

### At a Glance

- PowerSupply: 9-32VDC
- Power Consumption: 50 mA
- Operating Temperature  
-40 to + 85°C (-40 to 185°F)
- Storage Temperature  
-40 to + 85°C (-40 to 185°F)
- Reverse Polarity Protected
- Jump Start - ISO 15003-  
Section 5.14.2
- ISO 11452-2. 80MHz - 1000MHz,  
100v/m category C
- Load Dump - ISO 7637-2:2004  
AMD1: 2008 24V System Level 4
- EMS - ISO 7637-2:2004 AMD1:  
2008 24V System Level 4
- EMI - CISPR 25, ISO 14982
- ESD - ISO 10605: 2008 ±8kV  
contact, ±15kV air
- Water Tightness - IP67 with  
connector
- Chemical Compatibility - SAE  
J1455 - Section 4.4
- Mating Delphi Metri-Pack  
Series Connectors:  
#12162210 - 6 pin  
#12162260 - 6 pin  
#12162261 - 6 pin
- Mating Delphi GT Series 150  
3.5mm Centerline Connectors:  
#15491547 - 3 pin  
#15373426 - 3 pin