

# ACP PEDAL

ADVANCED COMPOSITE PEDAL

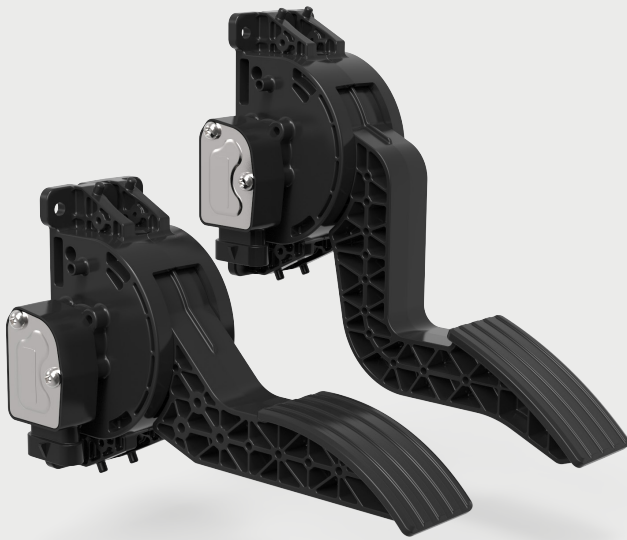

## AT A GLANCE

- > A COMPACT, LIGHTWEIGHT PEDAL OF COMPOSITE CONSTRUCTION, SUITABLE FOR ANY TYPE OF OFF-HIGHWAY OR ON-HIGHWAY VEHICLE APPLICATION REQUIRING A SUSPENDED, ELECTRONIC THROTTLE PEDAL
- > PASSIVE PERFORMANCE WITH COMPLETE RELIABILITY, MEANS THAT THE ACP PEDAL CAN BE INSTALLED AND SIMPLY FORGOTTEN ABOUT
- > PERFORMANCE SPECIFICATION BASED ON KONGSBERG AUTOMOTIVE'S BENCHMARK INDUSTRIAL PEDAL SPECIFICATION
- > vSENSE™ HALL EFFECT NON-CONTACT SENSOR PROVIDES POSITION SENSING AND SWITCHING

## PRODUCT DESCRIPTION

The Kongsberg Automotive ACP mechatronic pedal offers easy installation for suspended applications and provides unsurpassed reliability regardless of duty cycle and environmental conditions.

The ACP pedal features the vSENSE™ non-contact sensor with patent-pending technology, configurable for a wide range of sensor output types. Built to exceed all applicable industry standards and requirements, this rugged pedal and sensor system can withstand extreme environments while ensuring precise control and superior performance.

The Kongsberg Automotive vSENSE™ non-contact, programmable Hall effect sensor seals out contaminants to provide enhanced reliability in all environments. With no moving parts to wear over time, the vSENSE™ sensor sets a new standard for accuracy and durability.





## PRODUCT SPECIFICATIONS

PARAMETERS	SPECIFICATIONS
RATED LIFE	10,000,000 CYCLES
LOAD RATING	900N (202LB)
SPECIFICATION COMPLIANCE	FMVSS124, SAE J1455, SAE J1113
OPERATING TEMPERATURE	-40°C TO +85°C

## FEATURES

- > 18° PEDAL TRAVEL FROM THE REST POSITION
- > INNOVATIVE HOUSING DESIGN WITH LARGE BEARING DIAMETER PROVIDES EXCELLENT ABILITY TO WITHSTAND VERY DIRTY VEHICLE ENVIRONMENTS
- > EASY MOUNTING
- > INTEGRATED SENSOR WITH METRIPACK 150 CONNECTOR

## OPTIONS

- > AVAILABLE IN 'HIGH' OR 'LOW' PIVOT OPTIONS
- > TWO SENSOR OUTPUT CHANNELS CAN BE CONFIGURED FOR ANALOGUE, SWITCH OR PWM OUTPUTS, DEPENDING UPON THE VEHICLE REQUIREMENTS
- > ALTERNATIVELY, THE PEDAL CAN BE CONFIGURED TO PROVIDE A CANBUS OUTPUT

