

Electronic Systems

KEYLESS IGNITION MODULE



AT A GLANCE

- Completely replaces conventional mechanical key switches
- Suitable for use with mechanically and electronically controlled engines
- Adjustable backlighting for day/night time operation
- Status LED's indicate operating mode
- Fully sealed to IP67
- Excellent resistance to chemicals
- Compact & easy to install

The Keyless Ignition System is designed to replace traditional mechanical key switches on industrial vehicles and equipment. This compact, fully sealed single component system uses solid-state switching devices to provide extended service life in the harshest environments.

A Four to Eight digit Security code offers theft protection while eliminating the chance of misplacing the vehicle's keys. Convenient push to start and push to stop operation, with status LED's to indicate the operating mode. Ignition/Accessory outputs are also controlled with the pushbuttons. A Secondary security code provides access to devices connected to Ignition/Accessory outputs without the ability to start the engine, ideal during vehicle maintenance.

This device can be used as a stand alone product or it can be used in conjunction with other Megalink™ products to create a full scale multiplex control system for virtually any type of on-road or off-road vehicle.

MEGALINK™

Europe: Christopher Martin Road, Basildon, Essex SS14 3ES, UK
 North America: 300 S. Cochran PO Box 588 Willis, TX USA
 Electronics: 90 - 28^e Rue Grand-Mère (Québec) G9T 5Z8 Canada
www.kongsbergautomotive.com

Tel: +44 (0) 1268 522 861
 Tel: +1 936 856 2971
 Tel: +1 819 533 3201
 email: info.pps@ka-group.com

PRODUCT SPECIFICATIONS

SPECIFICATIONS & TECHNICAL DATA

- Operating Voltage: 6 - 20V or 8 - 32V
- Operating Temperatures: -20°C to +85°C.
- Storage Temperature: -40°C to +85°C.
- Maximum overall current: 5A - Requires an external fuse (medium acting or faster).
A circuit breaker is not suitable
- Tach input: Accepts 2, 3, 4 or 6 pulses per engine revolution
Configurable with the keypad
- Water resistance: P67 (1 meter under water)
- Electrical protection: Load Dump, 12V / 24V jump start & reverse polarity, ESD
- Connector: Integrated 8pin Deutsch DT series connector
Requires DT06-8S mating part

ELECTRICAL CONNECTIONS

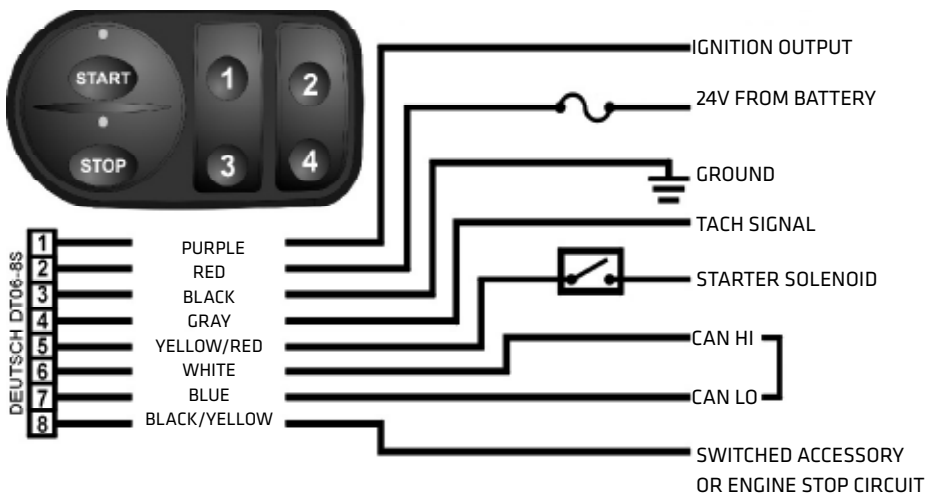

MOUNTING DETAILS

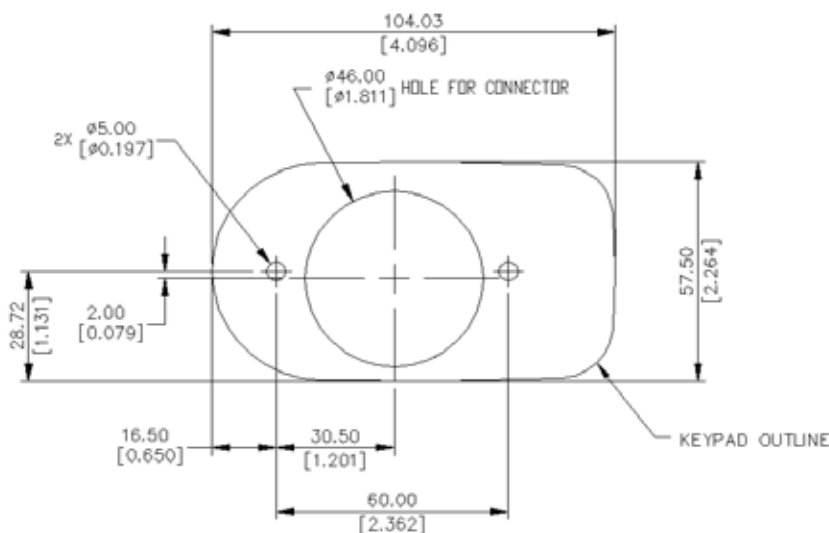

- Compatible with most engine types
- Models available for both 12V and 24V electrical systems
- Power management feature to shut off accessory output when battery voltage falls below 11.9V on 12V systems and 23.8V on 24V systems when engine is not running. This prevents battery drain and provides a reserve for starting the engine
- Primary security code provides full authority
- Secondary code provides limited functions
- Starter protection feature - starter output is disabled when engine is running - maximum continuous cranking time
- Starter Solenoid Output: - 5A max.
- Ignition Output: - 5A max.
- Accessory Output: - 5A max. (Optional)
- Less than 1mA standby current