

Electronic Systems

11 SWITCH KEYPAD



AT A GLANCE

- Now available for 12/24V applications
- Easy to connect to any CAN based system
- Compatible with J1939, RVC or other CAN protocols
- Switch icons are easily customised to suit specific applications
- Real-time activation/status
- 33 status LED's
- Dimmable backlight LED's for day/night time operation
- Low power sleep mode current drain < 1mA
- Fully sealed to IP67
- Excellent resistance to chemicals

The 11 switch keypad is a highly versatile design which is compatible with the full range of Megalink™ multiplex control modules. This allows a complete system or subsystem in wide range CAN based vehicles and applications to be quickly and easily created. Alternatively the keypad can simply be incorporated into a vehicle's existing CANbus. Its generic slave configuration, which is common to many CAN based applications, allows the vehicle application to take full control of the keypad and give each switch its own characteristics.

Up to 33 LEDs can be used for displaying the switch status or vehicle diagnostics. The LEDs can easily be configured for various diagnostics determined by the application or the user's needs. An additional 13 backlight LEDs can be controlled individually (not controlled individually) and are dimmable to suit day/night operation. Laser etching of the icons on the silicone membrane provides customization to suit a specific application quickly and cost effectively. In sleep mode, this unit draws less than 1mA and has a bi-directional wake-up pin used to wake up the system or be woken up by the system.

This compact, fully sealed and ruggedised unit will provide extended service life in the harshest environments.

Europe: Christopher Martin Road, Basildon, Essex SS14 3ES, UK
 North America: 300 S. Cochran PO Box 588 Willis, TX USA
 Electronics: 90 - 28^e Rue Grand-Mère (Québec) G9T 5Z8 Canada
www.kongsbergautomotive.com

Tel: +44 (0) 1268 522 861
 Tel: +1 936 856 2971
 Tel: +1 819 533 3201
 email: info.pps@ka-group.com

PRODUCT SPECIFICATIONS

SPECIFICATIONS & TECHNICAL DATA

- Operating Voltage: 6 - 32 VDC
- Standby Current: <1mA
- Operating Temperature: -40°C to 85°C.
- Storage Temperature: -40°C to 85°C
- Water resistance: IP67 (1 meter under water)
- Electrical protection: Load Dump ISO 7637 200VDC
ESD: ISO 10605 (\pm 15kV air and contact)
Cold start: ISO 16750-2 (down to 5V)
12/24V jump start: ISO 16750-2 (36V)
Reverse polarity and short circuit: ISO 16750-2
Conducted transients: ISO 7637 (Pulse 1, 2a, 2b, 3a, 3b)
- Diagnostics: Application has full access to the LEDs to display various Diagnostics.
- Connector: Integrated 6 pin DT series Deutsch
- Dimensions: 150mm x 60mm x 19mm (6" x 2-3/8" x 3/4")

ELECTRICAL CONNECTIONS:

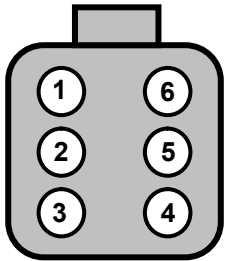

View on rear of keypad

Deutsch DT 6 pin connector - DT06-6S mating part required.

1. Shield
2. V+ (Battery +)
3. Ground (Battery -)
4. CAN Hi
5. CAN Lo
6. System Wake Up

MOUNTING DETAILS

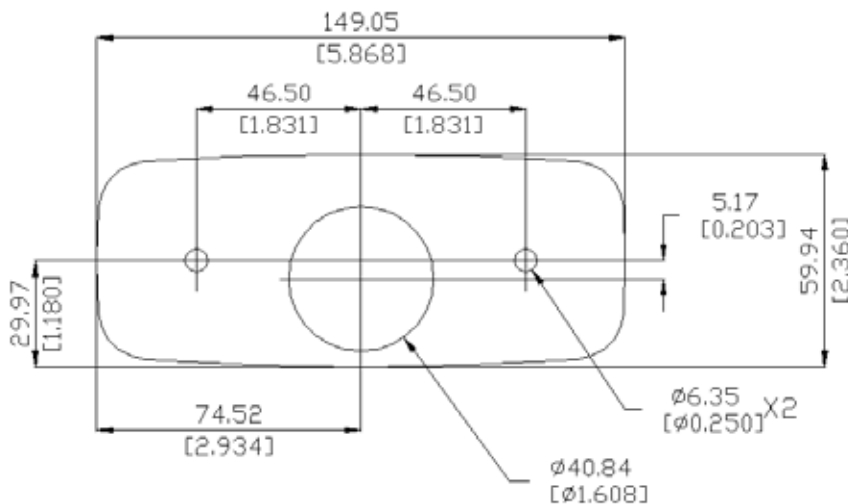

OPTIONS:

- Full 8 bits 8 MHz micro-controller enables the use of most protocols
- Field flashable memory
- CAN network compatible
- Panel mount or flush mount installation
- Horizontal or vertical orientation
- Tested to over 1 million cycles