



# General Injection Mould Specifications

**KONGSBERG AUTOMOTIVE GROUP**

Edition 3  
19.06.2013

## CONTENT

### **A: GENERAL STATEMENT**

### **B: STEEL/COLUMN/STANDARD ELEMENTS**

STEEL  
COLUMN  
STANDARD ELEMENTS

### **C: TECHNICAL CHARACTERISTICS**

#### **I- MOULD BASE**

GENERAL

#### **II- MOULD CAVITIES**

GUIDING

#### **III- ASSEMBLING**

EYE BOLT AND HOLE  
HANDLING BARS  
MOULD CLAMPING  
CROW BARS LOCATION AND DIMENSIONS  
CENTERING

#### **IV- COOLING SYSTEM**

CONNECTORS  
TUBE DISTRIBUTOR  
BLADE SEPARATOR  
SEALING

#### **V- CAVITY FEEDING**

COLD RUNNER DESIGN  
BUSHING  
HOT RUNNERS

#### **VI- KINEMATICS**

SLIDES, HYDRAULIC CORES AND ANGLE EJECTORS - GENERAL  
MOVEMENTS  
EJECTION  
HYDRAULIC SYSTEM

#### **VII- OTHERS TOPICS**

TIME STAMPS  
MECHANICAL CYCLE COUNTER  
MOULD IDENTIFICATION  
VENTINGS

## **A: GENERAL STATEMENT**

1. Deviations from this tooling specification or special requirements have to be stated when making offers.
2. Tooling development must not be started before approval of tooling layout and time schedule have been approved by Kongsberg Automotive. The time schedule is to be sent together with the order confirmation.
3. Any defects in the tooling or dimensional deviations originating in the tooling are to be remedied by the tooling supplier in question. In cases like these, freight costs will be debited the tooling supplier. If the tooling cannot be sent to the tooling supplier, Kongsberg Automotive will call on another tooling manufacturer, and possible costs will be debited the original tooling supplier (by agreement between Kongsberg Automotive and the tool maker).
4. In all communication with Kongsberg Automotive, project number, description and part number have to be stated.
5. Drawings/models of tooling and electrodes belong to Kongsberg Automotive and have to be delivered together with the tooling. Kongsberg Automotive is the owner of the tooling design. Drawings/models have to be delivered on a CD in a neutral format or an agreed format, 2D has to be made available in paper copy.
6. Certificates of steel grades and hardening process have to be supplied to Kongsberg Automotive as soon as possible.

## B: STEEL/COLUMN/ STANDARD ELEMENTS

### STEEL

Europe Steel std. * Sweden std SS 2242 ** Stavax 2314	Reference DIN									
	Similar stainless steel			Hasco	Std mould base steel	Impact & hotrunner plate	Std mould base steel high volymes tool	Std mould base steel		Hasco or Rabourdin, Cumsa, DMS
	1.2343	1.2344*	1.2083**	1.2767	1.1730	1.2312	1.2311	1.2099	1.2085	
Hardness in HRC	51±1		50±1		36±1	32±1	41±1			
Mould base					X			X	X	
Plates (fix plates)						X	X	X	X	
Cavities/inserts	X	X	X	X						
Mould pins										X
Mould sliders	X	X	X	X						

China Steel std. *AISI P20 **AISI P20HH	Reference SCHMOLZ+BICKENBACH(S+B)									
	Similar stainless steel			Hasco	Std mould base steel	Impact & hotrunner plate	Std mould base steel high volymes tool			Punch Misumi.
	2343ESR	2344ESR	2083ESR	2767	S45C	2311*	2738H**			
Hardness in HRC	46-54	46-54	46-54	50-54	28-30	28-32	33-37			
Mould base					X	X	X			
Plates (A.B)					X	X	X			
Plates (Ejector)					X	X	X			
Cavities/inserts	X	X	X	X			X(soft tooling)			
Mould pins										X
Mould sliders	X	X	X	X			X(soft tooling)			

### COLUMN

For all the mould with a temperature higher than 100°C with must have ring with Bronze graphite

### STANDARD ELEMENTS

Standard elements must be from **HASCO** (Rabourdin, Cumsa or DMS are also acceptable)  
Check RFQ for more information.

## **C: TECHNICAL CHARACTERISTICS**

### **I - MOULD BASE**

#### **GENERAL**

1. For mold bases Hasco (or Rabourdin, Cumsa or DMS) parts are to be used. In case this is not possible, standard parts approved by Kongsberg Automotive are to be used.
2. The steel grade of the Mold base has to be DIN 1.1730, unless otherwise stated in the RFQ/Order. (see also table steel)
3. Tooling for injection molding machines up to and including 500 tons are to be prepared for quick clamping. See att. drawing Mould std.001.001 and 002.001. All tooling is to be equipped with a clamping edge. The thickness of the backing plate has to be 27, 36, 46 or 56 mm, or factory requirement.
4. A transport locking device has to be fitted on the operator side of the tool.
5. In order to facilitate the disassembly of the tool, slots are to be milled in the corners of the rulers and in the parting lines.
6. All edges and corners are to be chamfered 2x45°.
7. The tooling needs to be manufactured in such a way that it can be put down on the floor without the danger of connectors, cylinders, etc. being damaged. Exceptions are only admissible if previously agreed upon with Kongsberg Automotive.

### **II - MOULD CAVITIES**

1. 25% of the tolerances of the part drawing may be used for tooling manufacture. 60% of the part tolerance regarding thickness of material may be used for tooling manufacture. Draft angle can not intrude upon the tolerance range. Any deviations must be approved by Kongsberg Automotive.
2. Any draft on textured surfaces has to be in accordance with the recommendations of R&D. Kongsberg Automotive is responsible for ensuring that the draft is sufficient for the pattern in question. It is the tooling manufacturer's responsibility to must give warning if irregularities are discovered.
3. The tooling manufacturer is responsible to ensure the part can be ejected without any damage to the part, or any deviation from the normal process to form-strip the part. Therefore, deep ribs, walls and pipes have to have a high degree of surface finish, some walls may have to be laid bare.
4. The mould cavities need to be vented in accordance with the drawing. Deep ribs and pipes may need to be vented through loose inserts or ejectors.
5. The steel grade for mold cavities and form giving parts will be specified in the inquiry/order.

6. If there is more than one mold cavity, the cavities have to be marked with a mold cavity number. The placing of the mark is specified on the drawing. However, if this is not the case the marking is to be placed as close to the gate as possible.

7. Parts have to be also marked with:

- KA part number
- Raw material
- Cavity nr. ( see above point 6)
- Time stamps ( if possible)

8. Critical inserts should be easy to loose so it is possible to adjust them, also when inserts has a position between each other needed to be adjustable to keep tolerance between them.  
To be agreed with Kongsberg Automotive.

## **GUIDING**

1. All guiding parts have to be made by Hasco standard. If this is not possible, the approval by Kongsberg Driveline Systems is required.

2. Guide pins for the guiding of mold halves have to be of such a height that when the mold is closed they enter the opposite half before any other parts of the tooling meet.

3. One of the guide pins needs to have a larger diameter to prevent the mold from being assembled the wrong way.

4. Additional guides need to have a less wide guiding (smaller angle) than the smallest shut-off (steel meeting).

5. Guide pins are to be equipped with oil grooves.

## **III - ASSEMBLING**

### **EYE BOLT AND HOLE**

1. It is necessary to be able to lift the tool as well as the separate tooling halves to let them hang vertically. Corresponding lift points have to be fitted on the bottom of the tool. Backing plates are to be equipped with four threaded holes for lifting eye bolts; holes for quick clamping may be used.

2. The tools have to be equipped with lifting eye bolts standard DIN 580/582

3. If needed to have the tool hanging 1-4 degrees with cavity side down. Factory agreement.

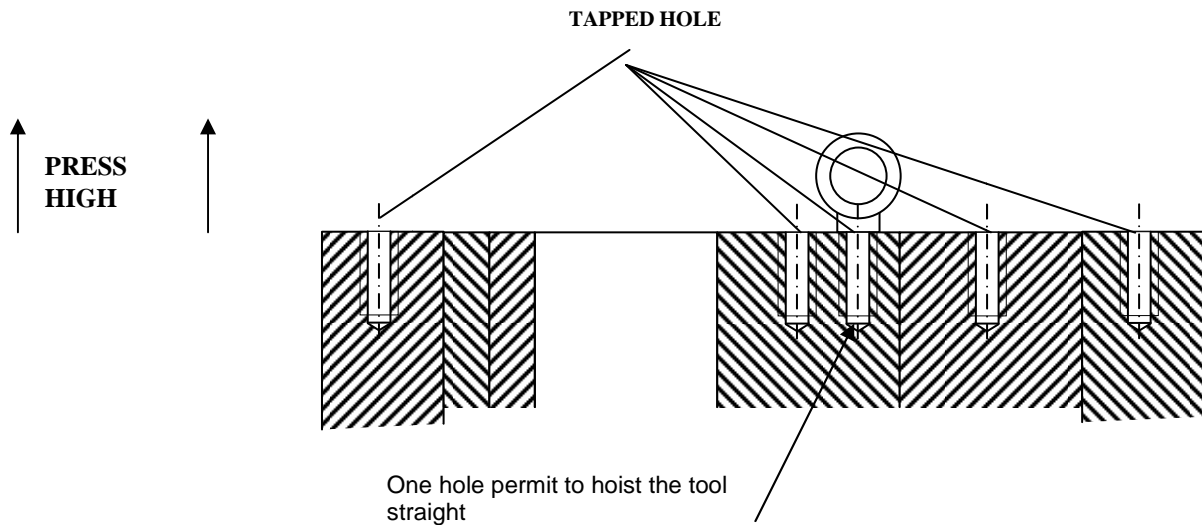

One hole on the 4 faces of each plate for plate with a weight higher than 10 Kg.

**IMPORTANT : Hole M14, M18, M27 forbidden**

## HANDLING BARS

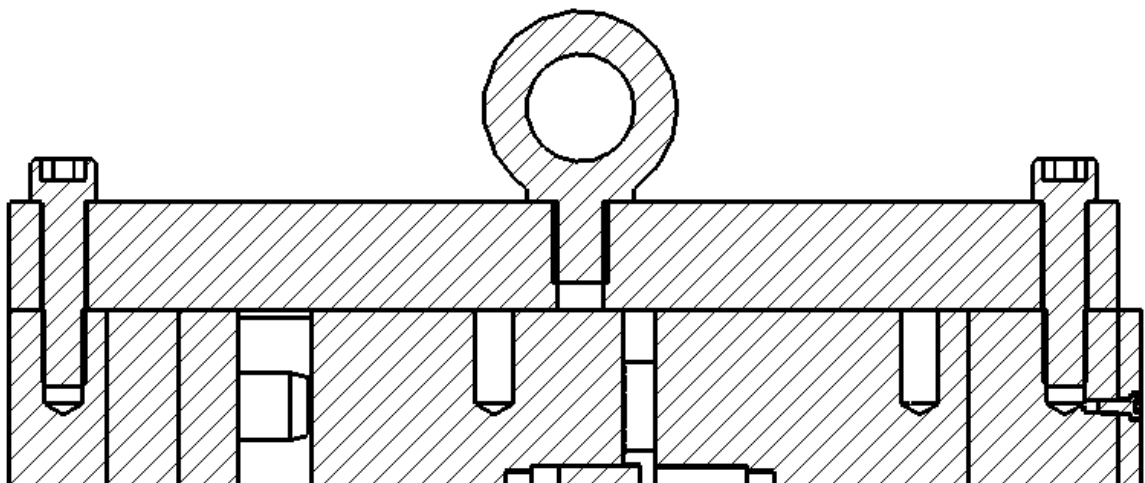

## MOULD CLAMPING

The clamping of the mould must be with overflow plate or with machining plate

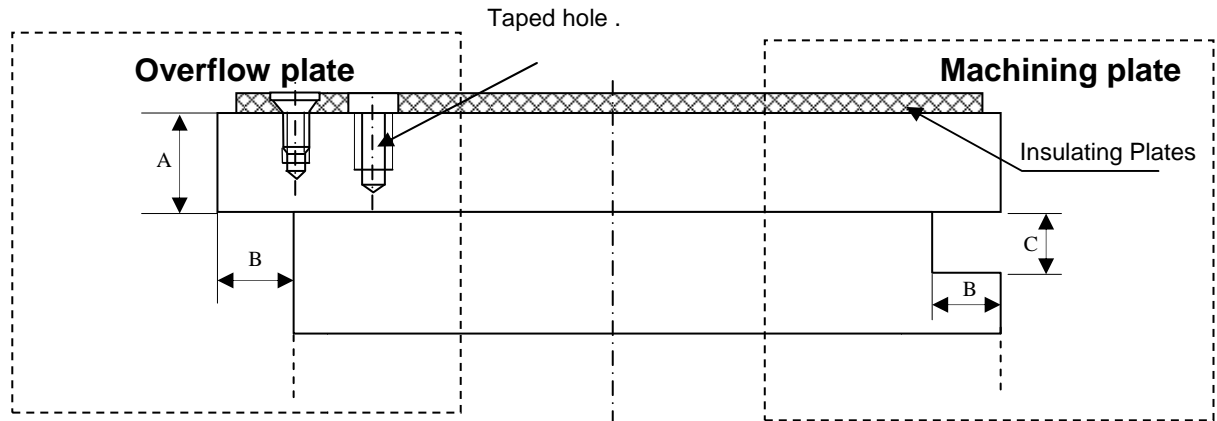

DIMENSION for injection moulding machine type:

Injection mould machine	A	B	C
Small machine	27	25	30-35
	36	25	45
Big machine	46	25	45
	56	30	50

## Insulating plate

- Use insulating plate with a thickness of 6mm ( 9 mm)
- Screw the insulating plate with screw 4 X FHC M6 X 16.
- Chamfer the plate with a 45° angle
- Clamping plate fasten element must be free open hole so not needed to remove insulation plate.
- All tools shall have insulation plate.



## CROW BARS LOCATION AND DIMENSION

- Crow bars must be 4 mm of depth on each plate.
- 2 types of machining:

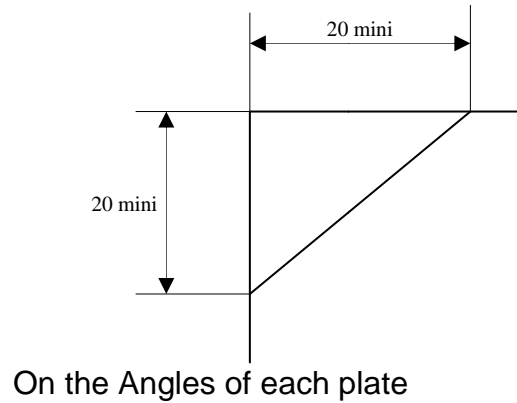
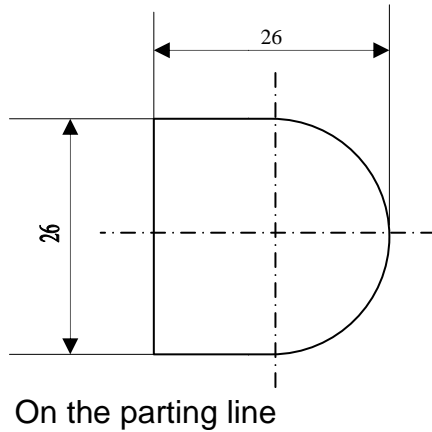

## CENTERING

### RING STANDARD FOR PRESS 25 to 250T

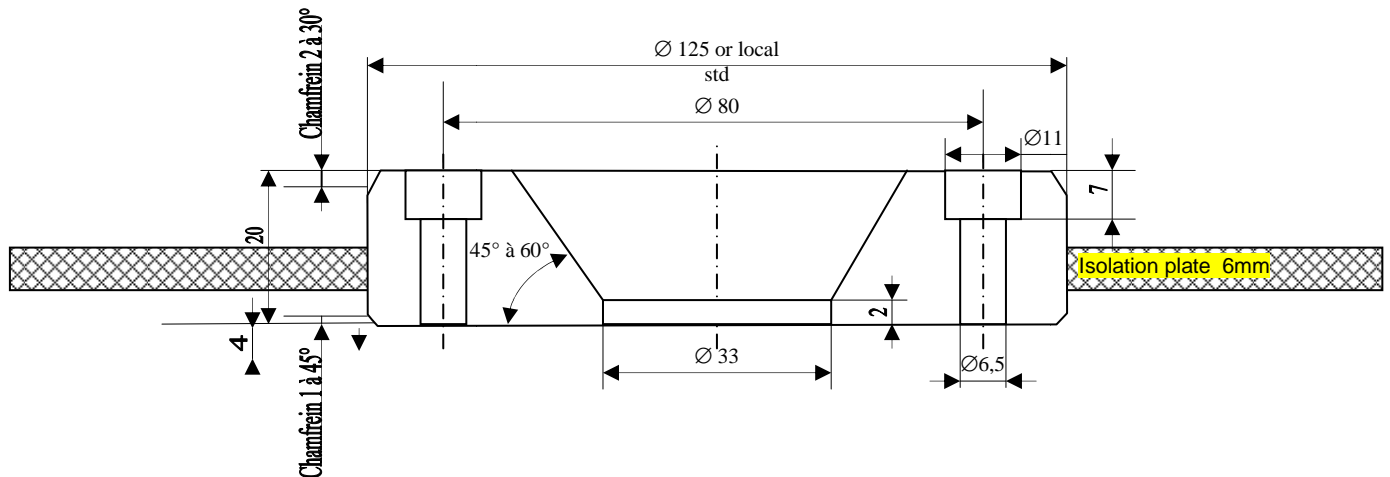

1. A Guide ring/Centre ring has to be fitted on fixed half of all tooling. For dimensions See the machine data sheet.

2. A transport locking device has to be fitted on the operator side of the tool.

3. When the mould is taller than 400kg, the mould must have a centering ring on the both side of the mould (ejection side and injection side) also in some other cases but then have to be specifying in enquiry/order.

## IV - COOLING SYSTEM

1. Cooling coils are to be placed in such a way and have to have such dimensions that an even a molding temperature is reached.
2. Water nipples are to be of Hasco type Z81/9/10x1 or Z81/13/R1/4 – to be agreed with Kongsberg Automotive, or Staubli due to below description and photo:

## CONNECTORS

To be agreed with Kongsberg Automotive.

3. Water nipples preferably need to be placed on the back of the tooling (when hanging in machine). The nipples must not protrude beyond the backing plates. If this would be the case, the connections have to be recessed. Deviations may be allowed if previously agreed upon by Kongsberg Automotive.
4. Cooling coils are mandatory to be marked IN/UT. If there are several coils, they are to be marked IN1, UT1, IN2, and UT2 and so on. All connectors need protection in tool bottom area to prevent damage.
5. If Ampco is used in areas/cores which are difficult to cool, the cooling coil/cooling tower has to always pass the Ampco material.
6. At 1st shot/delivery the cooling coils are to be hydrostatically tested at 6 bars.

**The connectors must be recessed in a hole 28x28**

## TUBE DISTRIBUTOR

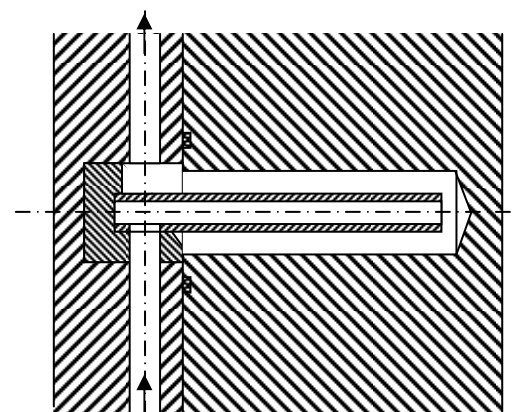
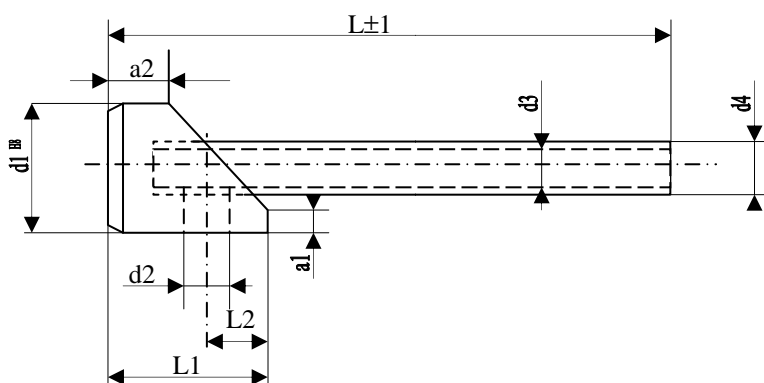

d1	d2	d3	d4	L1	L2	L	a1	A2
10	3,7	3	4	18	10	200	1,5	4,4
12	5,4	5	6	18	10	300	1,5	4,6
15	6,5	6	8	20	11	300	2,5	5,1
18	8,5	8	10	22	11	350	2,5	5,5
22	10,5	10	12	22	11	350	2,5	4,4

## BLADE SEPARATOR

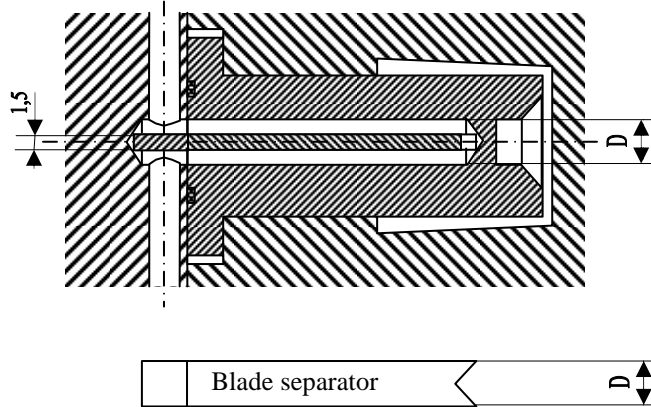

All the cooling line must be validated by Kongsberg Automotive.

### Standard cooling line

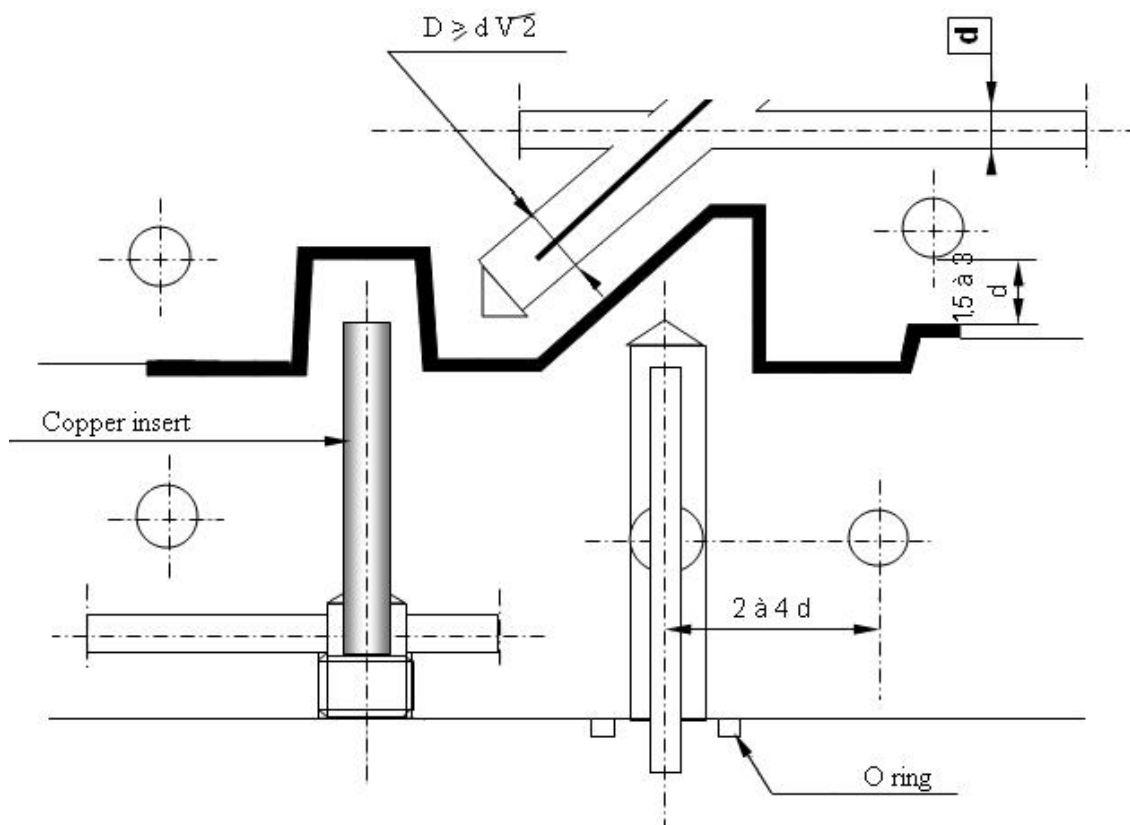

## SEALING

Cooling Line Diameter	O-Ring Reference	Tore	Inner Diameter	Outer Diameter	Drilling Depth
5	R5	1,9	5,7	9,5	1,6
6	R5 BIS	1,78	6,35	9,91	1,45
7	R6	1,9	7,2	11,00	1,6
8	R6 A	1,9	8,00	11,80	1,6
9	R8 BIS	1,78	9,52	13,08	1,45
10	R9	2,7	10,50	15,90	2,30
12	R10	2,7	12,10	17,50	2,30

USE VITON SEALING

## V - CAVITY FEEDING

### COLD RUNNER DESIGN

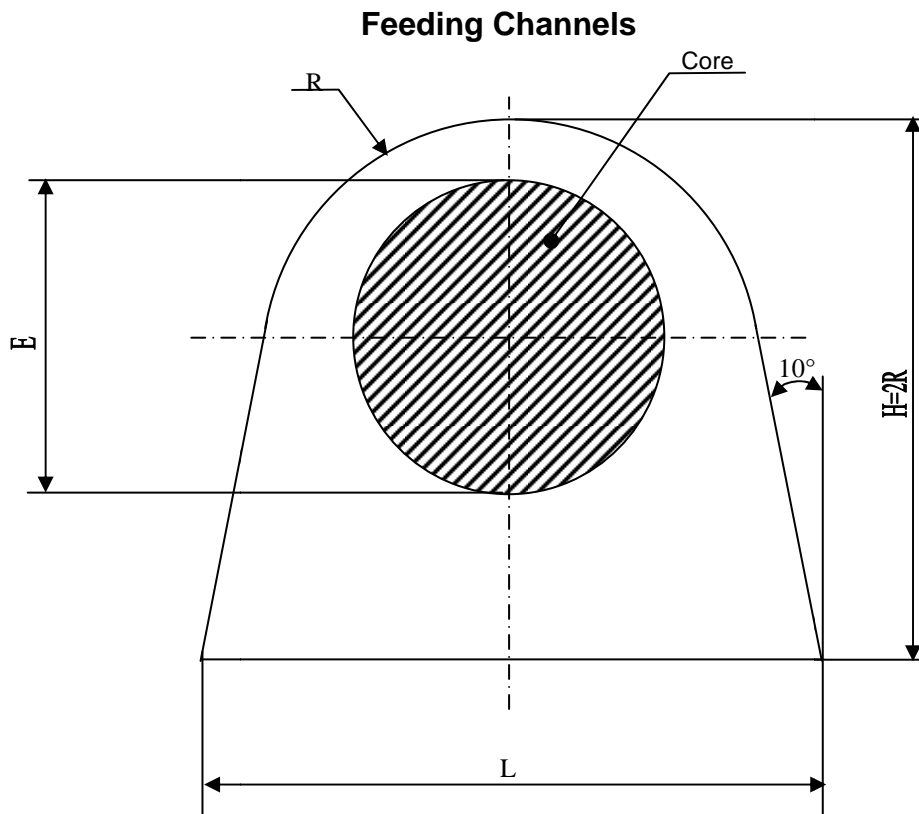

N°	R	H	L	E
1	1,20	2,40	2,86	1,60
2	1,50	3,00	3,58	2,00
3	1,70	3,40	4,05	2,25
4	1,90	3,80	4,53	2,50
5	2,10	4,20	5,01	2,80
6	2,25	4,50	5,36	3,00
7	2,70	5,40	6,44	3,60
8	3,40	6,80	8,10	4,50

## BUSHING

1. The sprue bush has to be standard type Hasco Z51 / Z511 or Z512.  
The bushing must be deep-hardened  $55\pm 2$  HRC. The radius of the bushing needs to be 15,5mm and the inlet hole at least 3,5mm. On certain tooling the radius must be larger, as specified in the inquiry/order.
2. Cold slug wells situated at ejectors have to be deeper than the tunnel or banana gates, if any, in order to control the process until the entire core has been laid bare.
3. The type of gate and its placing are to be agreed upon with Kongsberg Automotive.

**Angle standard :  $90^\circ$**   
**STEEL : acc. to DIN 1.2343**  
**USE STANDARD ELEMENTS.**

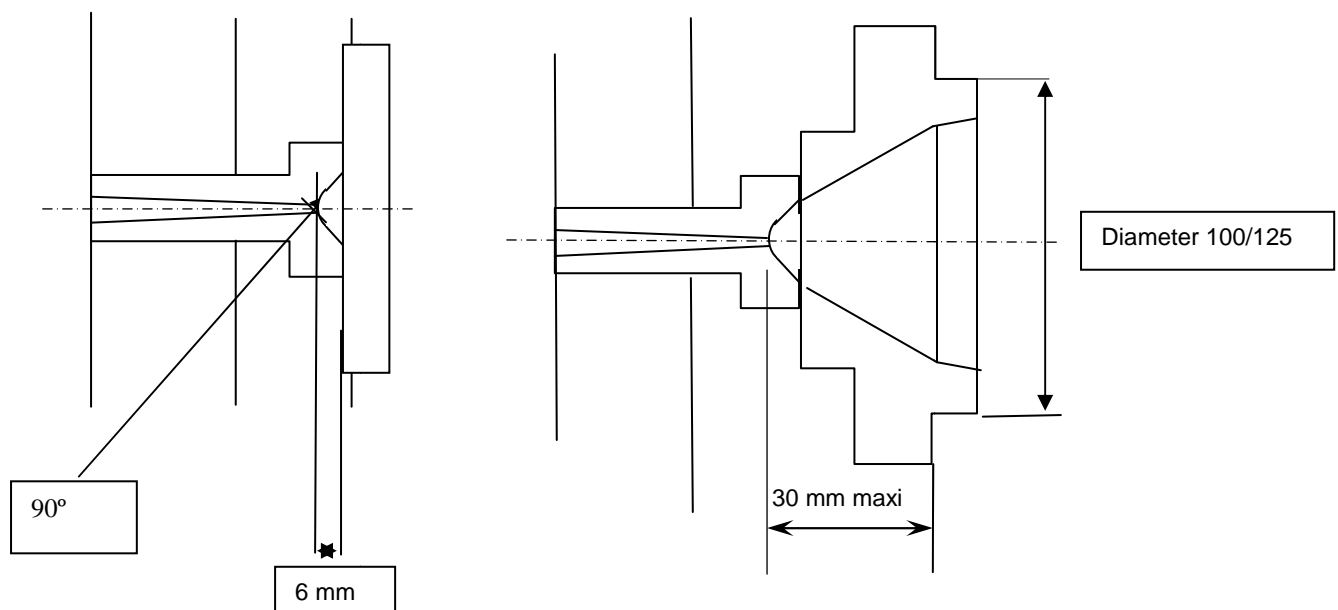

## **HOT RUNNERS**

1. The brand of the hot runner, if any, is to be made or to be made in accordance with the specifications of Kongsberg Automotive (see enquiry)
2. The hot runner is to be mounted in accordance with the recommendations of the supplier.
3. The tooling must to be marked with the name of the hot runner brand, if any.
4. The wiring diagram and layout must be available at the delivery of the tools.
5. The wiring between connector and hot runner has to be made such that the bolting plate can be disassembled without the wires having to be loosened.
6. Kongsberg Automotive will connect the hot runner, but the wires have to be marked that it is easy to see to which zones they belong.

## **VI - KINEMATICS**

### **SLIDES, HYDRAULIC CORES AND ANGEL EJECTOR - GENERAL**

1. All slides/cores are to be deed-hardened.
2. Mechanically run slides have to have distinct end positions through mechanical stops. As well as a ball with spring and/or a pressure spring to fasten the slide in the ejection position. Slides which are heavy enough to loosen from the ejection position through their own weight are to be secured by micro switches.
3. Slides able to collide with ejectors or other movable parts have to be secured by micro switches.
4. Wear plates for slides operated with angled pins shall have bigger angle than the pin.
5. Wear plates are to be bolted to enable adjustment. The plates need to be hardened and equipped with oil grooves.
6. The design of the angled ejectors has to be decided in conjunction with Kongsberg Automotive.
7. Hydraulically operated slides/cores must have micro switches to indicate in/out. Inductive disconnecting switches may be used if previously agreed with Kongsberg Automotive.
8. The fastening of the hydraulic slides has to be approved by Kongsberg Automotive.

## MOVEMENTS

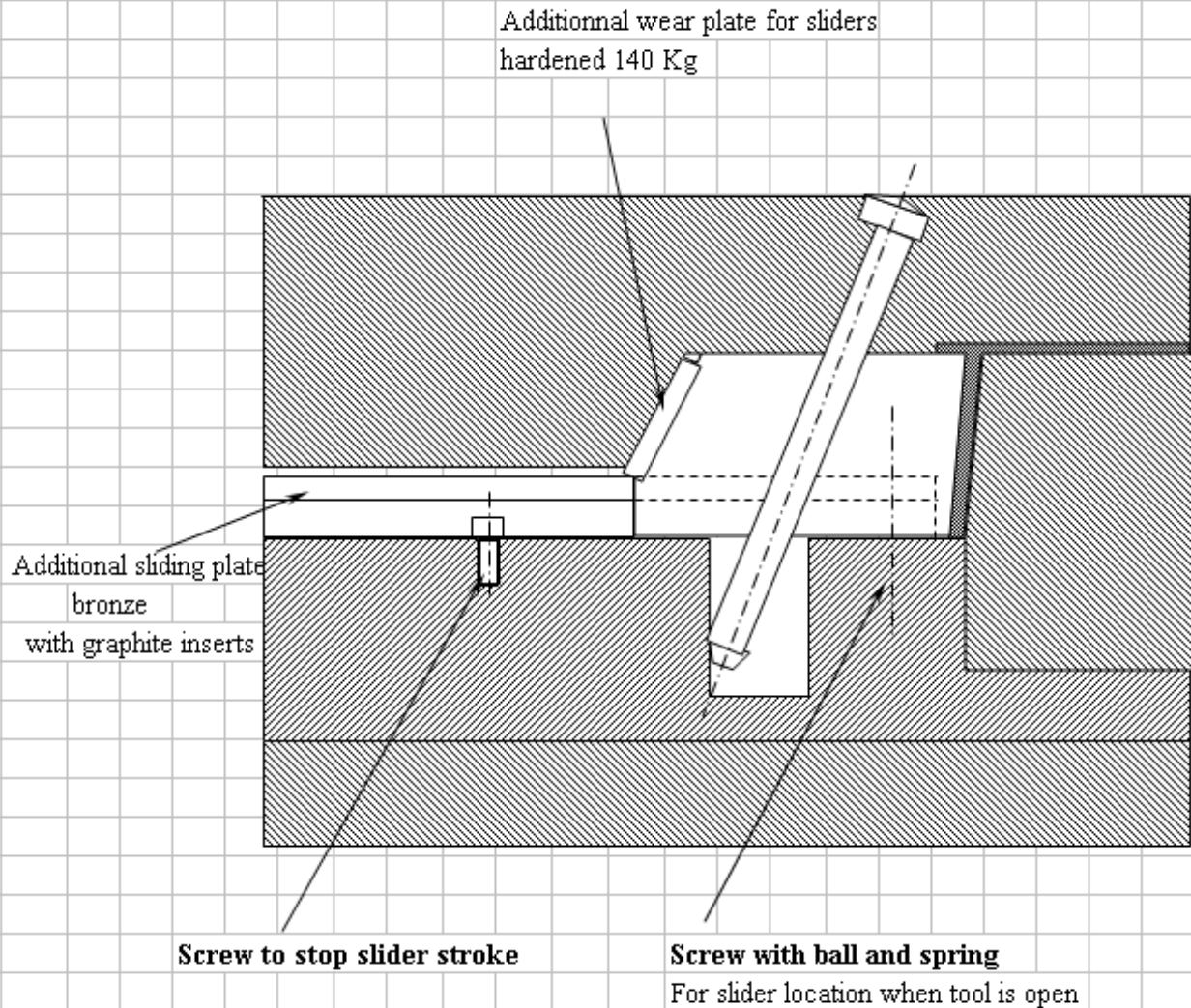

### **Mandatory**

Use clip DME device to ensure position when tool is open for sliders with weight > 10 kgs

Avoid sliders on top of mold

It must be possible to disassemble all moving parts when tool is on the molding machine.

Version inserts **must be screwed from the parting line** and fitted with angles to help disassembling.  
Threaded holes are requested to extract those inserts.

## EJECTION

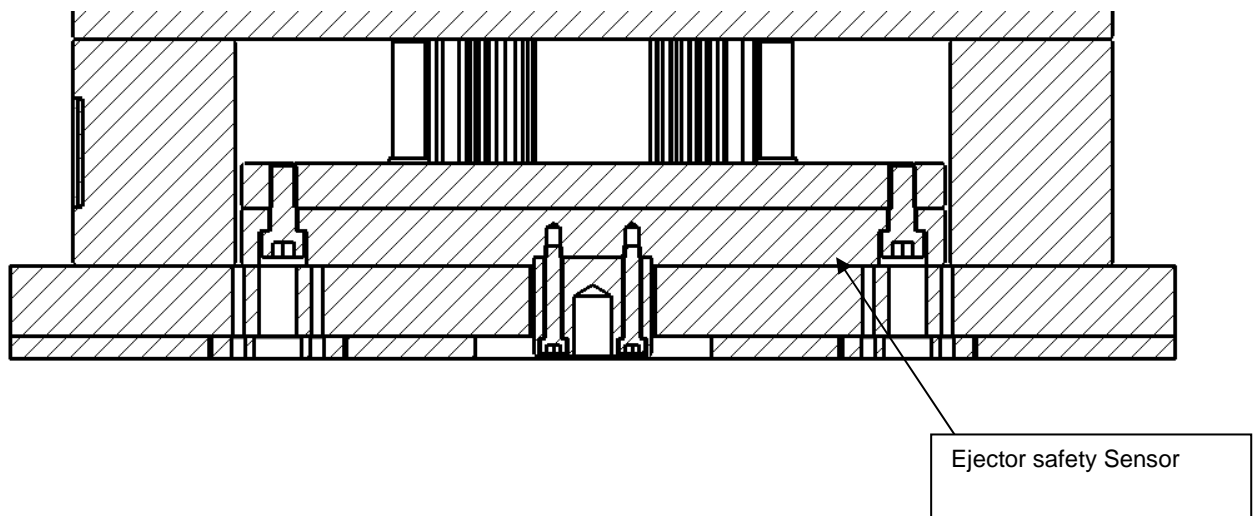

### **Place a sensor for ejection in case of core movement and slider.**

1. Ejectors have to be of the standard type Hasco Z41 and Z456. They are to be deep hardened (HRC 60) and nitrated ejectors may only be used if previously agreed upon by Kongsberg Driveline Systems.
2. Ejectors on an angled surface are to be locked to prevent rotation.
3. If it is possible the ejectors may collide with other movable parts, the ejection plate has to be detected by micro switches, in the rear position.
4. Guide pins for ejection are to be of a standard type, and they are only to be fastened to the backing plate.
5. The ejection plate needs to have at least four return pins. Additional return pins may be required if the ejector pin plate is longer than standard. Ejector return pins are to run clear.
6. The central connection of the ejection assembly needs to comply with above drawing or att. mould std.004. In some cases other designs may be used, but only if specified in the inquiry/order.
7. The design of the ejector pins to fix the part, if any, is to be agreed with Kongsberg Automotive.
8. The ejection length must be sufficient to uncover the entire part.

## HYDRAULIC SYSTEM

Hydraulic cylinders have to be made by Merkle, Mecman, Röhmeld, Bosch (with control of the end course sensor PNP) In case locking cylinders have to be used, they need to be of the Hasco or Staubli brand.

In exceptional cases other makes may be used if previously agreed upon with Kongsberg Automotive. Treats in the tool R 3/8, 1/4, or 1/2 with sharp edge so the sealing can work properly.



## VII - OTHER TOPICS

### TIME STAMPS

When marking with date clocks is required, they are to be of the standard Hasco (Cumsa or Rabourdin are also allowed – see other topics)

They have to be part of the straight model, which can be disassembled from the front.

If we have space 2 date clock: one fore year and one fore month.

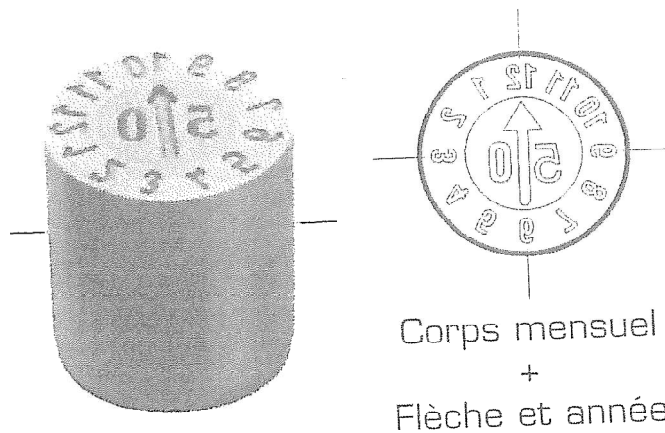

If you have a zone with enough space to place a grid month/year like the picture.

### MECHANICAL CYCLE COUNTER



Cumsa, DME, Hasco or equivalent.

### MOULD IDENTIFICATION

- KA Part reference
- Mould maker name
- Identification plate for hot runner.
- Weight of the mould

## VENTINGS

1. Ventings must be put in place after the first trail to avoid burned mark on the part.
2. The mould cavities need to be vented in accordance with the drawing 003.001(att.) or mould flow information. Deep ribs and pipes may need to be vented through loose inserts or ejectors. Avoid venting in sensitive splitting line.

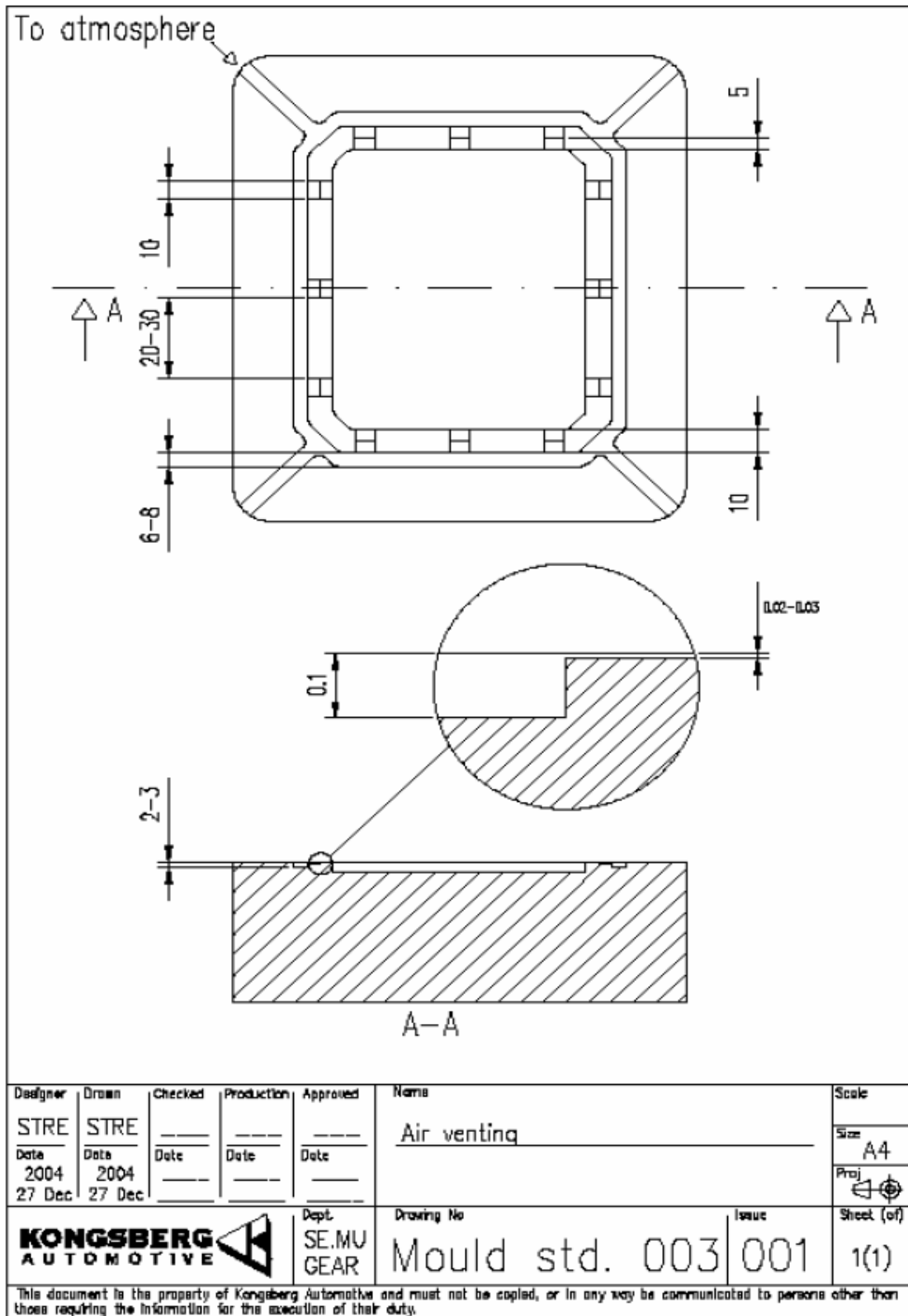

# General Injection Mould Specifications



Revision	Note								
0	0 = Prototype C=backingplate								
XXX	XXXXXX	___	___	X	XXX	___	___	XXXXXX	
Issue	Change No.	Vol. No.	Zone	Nature of change	Checked	Checked	Approved	Changed Date	
UNLESS OTHERWISE SPECIFIED		Dim tol.		Angle tol.	Radius tol.	Fillet radius	Sharp edges removed	Draft angle	Thread tolerances
± ___		± ___		± ___	± ___	R ___	QR or 45° 0.5x45	___	___
MATERIAL		Type		1650		MATERIAL		Tensile strength	
Std/spec n.		___		___		<input type="checkbox"/> Counterbored <input type="checkbox"/> Hightened 0.5 mm Tool: ___		VEM	
Base dim.		___		___		STATUS ON 3D MODEL <input type="checkbox"/> Complete / Valid <input type="checkbox"/> Simplified (see note above) <input type="checkbox"/> Does not exist		CAD SYSTEM Auto CAD	
SURFACE		All dimensions on drawing include surface treatment mentioned below		Treatment		FINISHES Ra $\sqrt{\quad}$ ( $\sqrt{\quad}$ )		REQUIREMENT CLASS marked with [ ] according to SE2112/101450	
Customer part no.		___		___		REFERENCE		Weight	
___		___		___		___		___ g	
Designer	Drawn	Checked	Production	Approved	Name				Scale
SBR	___	___	___	___	Central connection of ejection				1:1
Date	Date	Date	Date	Date	___				Size
20090110	___	___	___	___	___				A4
DD MM	___	___	___	___	___				Proj
___	___	___	___	___	___				☐ ⊕
		Dept. SE.MU SEAT		Driving No. Mould std.004		Issue 001		Sheet (x?) 1(1)	
This document is the property of Kongsberg Automotive and must not be copied, or in any way be communicated to persons other than those requiring the information for the execution of their duty.									

LAW PART 101450